

## Mobility & More, LLC Measurement Guide

It really is very easy to measure for a stairlift. All you need is a tape measure.

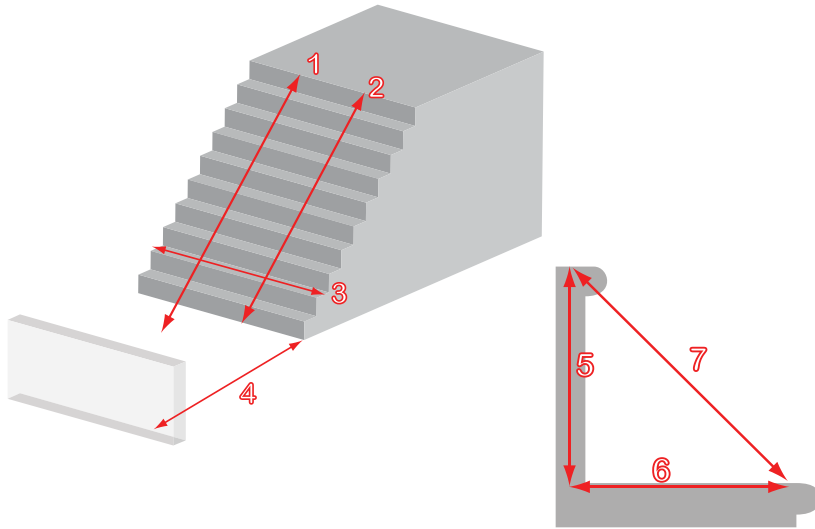

### Measurements

Looking up from the bottom of the staircase, which side of the staircase will the stairlift be mounted on?

Left  Right

1. Overall Length \_\_\_\_\_
2. Top stair to bottom stair \_\_\_\_\_
3. Staircase width \_\_\_\_\_
4. Bottom Clearance \_\_\_\_\_
5. Rise of one step \_\_\_\_\_
6. Tread of one step \_\_\_\_\_
7. Diagonal \_\_\_\_\_

Take a general overview of your stairway layout and decide which side of the staircase the stairlift will be mounted on, when viewed from the bottom. The lift may be mounted on the banister side if desired. No wall is necessary as the stairlift mounts to the stair treads, not a wall. Be aware that the stairlift rail will overhang the top landing by approximately 6" and meet the floor at the foot of the stairs approximately 14" beyond the nose of the first step. **All measurements should be recorded in inches.**

1. The most important measurement is marked as #1, Overall Length, on our guide below. This determines the length that we cut your rail for the lift. To obtain this measurement stand at the top of your stairs, extend your tape measure until it is laying on all the stair treads and the tip of the tape measure is touching the landing at the bottom of the steps.
2. Next measure from the edge of the top step to the edge of the first step. Mark this in block 2.
3. Next, measure the width of your staircase and enter the measurement into block 3, marked Staircase Width.
4. If there is a wall or a door at the bottom of the steps as illustrated as 4 on the diagram below, please measure from the bottom step to the wall.
5. The last three measurements (5,6,7) will enable us to preset the seat angle of your lift. Please measure each according to the diagram and enter the measurement results in the appropriate boxes.